

VILLAGE BOARD AGENDA

Plover Municipal Center Board Room
2400 Post Road
Plover, WI

Wednesday, May 6, 2026
6:00 p.m.

1. Call to order, Pledge of Allegiance.
2. Approval of the minutes of the meeting of April 15, 2026, as printed
3. Persons wishing to address the Board
4. Correspondence
5. Approval of vouchers

Discussion with possible action on the following:

6. Plan Commission Meeting of May 4, 2026
Item 5: Ordinance No. 5-8-26 Rezoning Request – Eric and Emily Krug – Rezone from Standard Single-Family residential District (R-2) to the Compact Single-Family Residential District (R-3) – 1717 Rose Court (PIN: 173230815-13.06)

Item 6: Resolution No. 5-8-26 – Certified Survey Map (CSM) – Eric and Emily Krug – 2 Lots – 1717 Rose Court (PIN: 173230815-13.06)
7. Approval of Hoover Ave. preventative maintenance
8. Approval of Equipment Purchases for Public Works, Water, and Wastewater
9. Poppy Day Proclamation
10. Class “B” Fermented Malt Beverage Retailers License Renewals
11. Shared-Ride Taxi Quarterly Report
12. Village project change orders, substitutions, or construction approvals
13. Engineer’s Report
14. Administrator’s Update
15. Adjournment subject to call of the chair

Village Board Meeting

Wednesday, April 15, 2026

6:00 p.m.

Members Present: Gary Wolf, Steve Fritz, Ross Ballard, Tim Durigan, Al Tessmann, Adam Raabe, Al Haga

Others Present: Steve Kunst, Julia Mann, Tammy Wojtalewicz, Lyle Lutz, Scott Klemm, Jake Hainzlsperger, Adam DeKleyn, Karmen Anderson, Joe Terry

1. Mr. Wolf called the meeting to order at 6:02 p.m. Pledge of Allegiance.
2. MINUTES
Mr. Haga motioned, and Mr. Raabe seconded, to approve the minutes of the meeting of March 18, 2026, as printed. Motion carried.
3. PERSONS WISHING TO ADDRESS THE BOARD - None.
4. CORRESPONDENCE - None.
5. APPROVAL OF VOUCHERS
Mr. Durigan motioned, and Mr. Raabe seconded, to approve the vouchers as listed. Motion carried.
6. RECOMMENDATION FOR APPROVAL OF ENGINEERING SERVICES AGREEMENT FOR THE RIVER RD. LIFT STATION UPGRADE
Mr. Haga motioned and Mr. Tessman seconded to approve the engineering services agreement for the River Rd. lift station upgrade for the low bidder. Motion carried.

VILLAGE OF PLOVER WASTEWATER TREATMENT FACILITY PLAN AMENDMENT –
DONOHUE & ASSOCIATES REPORT

Mr. Haga motioned and Mr. Raabe seconded to approve the Village of Plover Wastewater Treatment Facility Plan Amendment – Donohue & Associates Report. Motion carried.

SANITARY COLLECTION SYSTEM MASTER PLAN – DONOHUE & ASSOCIATES REPORT

Mr. Raabe motioned and Mr. Durigan seconded to approve the Sanitary Collection System Master Plan – Donohue & Associates report. Motion carried.

Mr. Wolf thanked Mr. Lutz for the work he put into submitting these three plans stating all the plans are necessary to move forward in the future if we have to prepare any

upgrades to the facility. One encouraging outcome of this plan is we currently do not have a predicted capacity shortage. If everything stays on track, we can implement incremental improvements each year and avoid a multi-million dollar expense at any one given time.

7. CHAPTER 447 SIGNS ORDINANCE AMENDMENT – UPDATING OFF-PREMISES SIGN/BILLBOARD STANDARDS

Mr. Tessman motioned and Mr. Raabe seconded to approve Ordinance 4-7-26 – Chapter 447 Signs Ordinance Amendment – Updating Off-Premises Sign/Billboard Standards.

Ms. Anderson addressed questions about what language was changed. Mr. Kunst noted the reasons for the amendment.

Motion carried.

CONDITIONAL USE PERMIT / SITE PLAN REVIEW – 4 SEASONS POWERSPORTS & SERVICE CENTER INC. – REQUEST TO OPERATE A POWERSPORTS SALES AND SERVICE BUSINESS WITH LIMITED OUTDOOR DISPLAY – 2850 POST ROAD (PIN: 1734214)

The Plan Commission took no action on this item, so no action was taken on this item by Village Board.

CONDITIONAL USE PERMIT / SITE PLAN REVIEW – ROBERT AND ASHLEY ALLEN – REQUEST TO ALLOW A RESIDENT DUPLEX IN THE B-2 GENERAL BUSINESS DISTRICT – 2940 PLOVER SPRINGS DRIVE (PIN: 17344C495)

Mr. Haga motioned and Mr. Tessman seconded to approve the conditional use permit / site plan review – Robert and Ashley Allen – Request to allow a resident duplex in the B-2 General Business District – 2940 Plover Springs Drive (PIN: 17344C495). Motion carried.

CONDITIONAL USE PERMIT – ACCESSORY STRUCTURE EXEMPTION – STEVE & PAULA WORZELLA – 1921 CLAR-RE DRIVE (PIN: 1736414)

Mr. Tessmann motioned and Mr. Haga seconded to approve the conditional use permit – accessory structure exemption – Steve & Paula Worzella – 1921 Clar-Re Drive (PIN: 1736414). Motion carried.

8. DAN R MAHONEY CONSERVANCY – DRIVEWAY IMPROVEMENTS AND NEW PARKING AREA

Mr. Fritz motioned and Mr. Haga seconded to approve the Dan R. Mahoney Conservancy – Driveway Improvements and New Parking Area. Motion carried.

9. CLASS “B” FERMENTED MALT BEVERAGE LICENSE AND “CLASS C” WINE LICENSE – MOEM HOSPITALITY, LLC, AGENT, MAURICE MOORE, BECCA’S CAFÉ – 1802 PLOVER RD, PLOVER, WI

Ms. Wojtalewicz reviewed the request.

Mr. Raabe motioned and Mr. Haga seconded to approve the Class “B” Fermented Malt Beverage License and “Class C” Wine License – Moem Hospitality, LLC, Agent, Maurice Moore, Becca’s Café – 1802 Plover Rd., Plover, WI. Motion carried.

10. “CLASS B” ALCOHOL BEVERAGE RETAIL LICENSE – C & R STONE HARVEST LLC, AGENT, RENEE PERZINSKI, STONE HARVEST WINE LOUNGE – 3252 MECCA DR., PLOVER, WI

Ms. Wojtalewicz reviewed the request.

Mr. Haga motioned and Mr. Raabe seconded to approve the “Class B” Alcohol Beverage Retail License – C & R Stone Harvest LLC, Agent, Renee Perzinski, Stone Harvest Wine Lounge – 3252 Mecca Dr., Plover, WI. Motion carried.

11. ULTIMATE MART, LLC – CHANGE OF RETAIL ALCOHOL BEVERAGE LICENSE AGENT, PEGGY FLAHERTY, FOR METRO MARKET #101 – 1850 PLOVER RD, PLOVER, WI

Ms. Wojtalewicz reviewed the request.

Mr. Tessmann motioned and Mr. Durigan seconded to approve the Ultimate Mart, LLC - Change of Retail Alcohol Beverage License, Agent Peggy Flaherty, for Metro Market #101 – 1850 Plover Rd, Plover, WI. Motion carried.

12. RESOLUTION 4-7-26 TO CLARIFY AND AMEND THE PAYMENT DATES FOR RESOLUTION NO 11-24-25 RESOLUTION AUTHORIZING THE ISSUANCE OF \$1,100,000 GENERAL OBLIGATION PROMISSORY NOTES AND THE ISSUANCE AND SALE OF A \$1,100,000 NOTE ANTICIPATION NOTE

Ms. Mann reviewed the request. The purpose of this resolution is to clarify we are only paying interest on the principle amount for the first two years of this note until we refinance the debt. Mr. Kunst added this was the intent of the original resolution.

Mr. Haga motioned and Mr. Tessmann seconded to approve Resolution 4-7-26 to clarify and amend the payment dates for Resolution No. 11-24-25 Resolution authorizing the issuance of \$1,100,000 General Obligation Promissory Notes and the issuance and sale of a \$1,100,000 note anticipation note. Motion carried by unanimous roll call vote.

13. ARBOR DAY PROCLAMATION

Mr. Wolf introduced the request. The tree planting event will be at Little Plover River Park. Several sponsors are assisting with this event. Mr. Klemm added they are gradually trying to replace more trees in the Village. There will also be trees planted in the conservancy.

Mr. Tessman motioned and Mr. Durigan seconded to approve the Arbor Day Proclamation. Motion carried.

14. 2026 COMMITTEE/COMMISSION APPOINTMENTS

Ms. Wojtalewicz distributed an updated list for Committee Appointments. Copy attached. Mr. Wolf reviewed the request.

Mr. Haga motioned and Mr. Fritz seconded to approve the 2026 Committee/Commission Appointments. Motion carried.

15. A. LAKE PACAWA PARK – PHASE 3 PROJECT – CHANGE ORDER NO. 8

Mr. Kunst reviewed the change order. One part of the change order covers two pickleball project items which will be covered by the Heart of Wisconsin Pickleball Association. The change includes some windsocks and a chiller for the water fountain. The other part of the change order is the Village working with an anonymous donor to do some revisions to the family bathroom near the baseball fields and splashpad area incorporating an adult size changing area to assist those with physical needs. Mr. Kunst added that Mike Helmrich of the Parks committee did a lot of research to get this put in. At the time the research was done the only places in Wisconsin that had something like this was Lambeau Field and American Family Field. This will be a positive addition designed for an obvious need and the cost to the Village will be minimal.

Mr. Haga motioned, and Mr. Tessmann seconded to approve Lake Pacawa Park – Phase 3 Project – Change Order No. 8. Motion carried.

B. LAKE PACAWA PARK – PHASE 3 PROJECT – CHANGE ORDER NO. 9

Mr. Kunst reviewed the change order. He noted this is not a financial contribution from the village. Due to pouring the concrete during (or just after) a rain some of the concrete near the pickleball courts has some aesthetic deficiencies but structurally looks fine. The contractor is providing a two-year warranty on the work. The Public Works department and Rettler both feel that is acceptable.

Mr. Haga motioned and Mr. Tessmann seconded to approve Lake Pacawa Park – Phase 3 Project – Change Order No. 9. Motion carried.

16. ENGINEER'S UPDATE

Mr. Terry reviewed his report. Copy attached. He highlighted the response received from the DNR regarding the Springville Dam. The DNR has agreed to meet in June to go over this. Mr. Kunst added we are on our third DNR staff contact regarding this issue, so this may be a circumstance of a new person with new eyes working on this. Mr. Haga feels someone from the DNR must have something mixed up since all the documentation from the past shows no indications of any of the things the DNR is now calling out. The current water flow readings were discussed.

17. ADMINISTRATOR'S UPDATE

Per Mr. Kunst's request, Mr. Klemm gave an update on the road projects and general timelines. Mr. Klemm highlighted the Black Forest Subdivision, the Twin Towers area, and the Village Park area. They will do the final paving on the River Drive, Bob's Dr. and Gloria's Dr. areas once school is out, so it doesn't impact the school bus. Mr. Klemm noted a lot of the roads took a hit over the last month and a half and commented that a lot of the materials aren't as good of quality as in the past based on how they are now made. Mr. Klemm also addressed work on the Green Circle Trail.

Mr. Kunst gave an update on the Hwy. 54 project. He noted the Fire and Police department staff met with the design team today to go over final finishings. He anticipates final bids will be coming before the board in May. He also notified the board of a meeting with our health insurance broker discussing a concept to evaluate for the future regarding a direct primary care option. He appreciates our broker looking for long-term solutions to continue offering quality health insurance options. The Celebrate Plover core team is beginning to meet regarding the Celebrate Plover event at the end of July.

Mr. Klemm added that the Public Works department is partnering with the United Way for National Public Works Week in May. They are looking to hold a Public Works Open House "Touch a Truck" type theme and tying it in with the United Way Diaper Drive. People can drop off diapers during the event and get an opportunity to see everything the Public Works Department does in the Village as well as see some of the equipment. This will be a great way to show people all they do as they do more than streets. They will be able to get to know the Public Works crew while also helping out the United Way. Mr. Kunst acknowledged Mr. Klemm and Mr. Hainzlsperger who wanted to partner with United Way to give back to the community.

Mr. Wolf noted the positive calls he has received from residents who are appreciative of the added hours to get brush and limbs picked up as well as the added hours at the compost site. Mr. Klemm noted they have been averaging about 40 loads of brush per day. He thanked Zbewski Bros. and Green Thumb for having sites they can take it to. They appreciate vendors who want to help them and the contractors who have helped

18. CONSIDERATION OF MOTION TO ADJOURN INTO CLOSED SESSION UNDER WI STATE STATUTE 19.86(1)(C) FOR THE PURPOSE OF CONSIDERING EMPLOYMENT, PROMOTION, COMPENSATION OR PERFORMANCE EVALUATION DATA OF ANY PUBLIC EMPLOYEE OVER WHICH THE GOVERNMENTAL BODY HAS JURISDICTION OR EXERCISES RESPONSIBILITY.

At 6:46 p.m. Mr. Tessmann motioned and Mr. Durigan seconded to adjourn into closed session under WI State Statute 19.86(1)(c) for the purpose of considering employment, promotion, compensation or performance evaluation data of any public employee over which the governmental body has jurisdiction or exercises responsibility. Motion carried by unanimous roll call vote.

19. Mr. Haga motioned and Mr. Tessmann seconded to adjourn at 7:19p.m. Motion carried.

Respectfully submitted by Tammy Wojtalewicz, Village Clerk

Report Criteria:

- Detail report.
- Invoices with totals above \$0.00 included.
- Paid and unpaid invoices included.
- [Report].GL Account Number (3 Characters) = {<>} "200"

Vendor	Vendor Name	Invoice Number	Description	Invoice Date	Net Invoice Amount	Amount Paid	Date Paid	Voided
100								
3885	AFFORDABLE AUTO GLASS LL	23946	BLAZER WINDSHIELD	04/22/2026	860.00	860.00	04/24/2026	
123	AMERICAN WELDING & GAS IN	11618255	WELDER TIPS AND PARTS	04/23/2026	180.00	180.00	04/24/2026	
137	ANDERSON OBRIEN LLP	259790	LEGAL FEES	04/20/2026	100.00	100.00	04/24/2026	
137	ANDERSON OBRIEN LLP	259791	LEGAL FEES	04/20/2026	325.00	325.00	04/24/2026	
137	ANDERSON OBRIEN LLP	259792	LEGAL FEES	04/20/2026	125.00	125.00	04/24/2026	
137	ANDERSON OBRIEN LLP	259793	LEGAL FEES	04/20/2026	125.00	125.00	04/24/2026	
154	APPLIED INDUSTRIAL TECHNO	7034385351	GRINDING WHEELS	04/20/2026	51.12	51.12	04/29/2026	
185	ASPIRUS INC	123694april	MARCH BLOOD DRAWS	04/01/2026	68.00	68.00	04/17/2026	
200	AT&T MOBILITY-PD FD CELL PH	287287239486	STEVES PORTION OF CELL BIL	04/07/2026	41.94	41.94	04/24/2026	
200	AT&T MOBILITY-PD FD CELL PH	287287239486	PD CELL PHONE BILL	04/07/2026	1,575.87	1,575.87	04/24/2026	
195	AT&T- NEW PHONES 831-001-20	5574824118	APRIL	04/17/2026	131.71	131.71	04/24/2026	
195	AT&T- NEW PHONES 831-001-20	5574824118	APRIL	04/17/2026	201.41	201.41	04/24/2026	
195	AT&T- NEW PHONES 831-001-20	5574824118	APRIL	04/17/2026	38.73	38.73	04/24/2026	
195	AT&T- NEW PHONES 831-001-20	5574824118	APRIL	04/17/2026	116.20	116.20	04/24/2026	
233	BADGER MOTORS AUTO SALVA	173989	DASH REBUILD TRUCK #19	04/23/2026	225.00	225.00	04/29/2026	
3701	BAUER BUILT INC	511017568	FRONT TIRES LEAF VAC	04/17/2026	665.00	665.00	04/29/2026	
3701	BAUER BUILT INC	511017598	LEAF VAC TIRE DISMOUNT/MO	04/23/2026	408.00	408.00	04/29/2026	
278	BEACON ATHLETICS	0633505-IN	SLOP GAUGE	04/15/2026	464.00	464.00	04/24/2026	
3916	BV NATIONAL ELEVATOR INSPE	26008384	2026 ELEVATOR INSPECTION	04/22/2026	110.00	110.00	04/29/2026	
447	CELLEBRITE INC	INVUS297999	CELLEBRITE TRAINING	04/27/2026	4,845.00	4,845.00	04/29/2026	
3535	CENTER FOR INTERNET SECU	INV-260402-00	2026 ANTIVIRUS	04/24/2026	2,046.00	2,046.00	04/24/2026	
3535	CENTER FOR INTERNET SECU	INV-260402-00	2026 ANTIVIRUS	04/24/2026	462.00	462.00	04/24/2026	
3535	CENTER FOR INTERNET SECU	INV-260402-00	2026 ANTIVIRUS	04/24/2026	132.00	132.00	04/24/2026	
3535	CENTER FOR INTERNET SECU	INV-260402-00	2026 ANTIVIRUS	04/24/2026	66.00	66.00	04/24/2026	
3535	CENTER FOR INTERNET SECU	INV-260402-00	2026 ANTIVIRUS	04/24/2026	66.00	66.00	04/24/2026	
3535	CENTER FOR INTERNET SECU	INV-260402-00	2026 ANTIVIRUS	04/24/2026	66.00	66.00	04/24/2026	
3535	CENTER FOR INTERNET SECU	INV-260402-00	2026 ANTIVIRUS	04/24/2026	462.00	462.00	04/24/2026	
3535	CENTER FOR INTERNET SECU	INV-260402-00	2026 ANTIVIRUS	04/24/2026	132.00	132.00	04/24/2026	
3535	CENTER FOR INTERNET SECU	INV-260402-00	2026 ANTIVIRUS	04/24/2026	132.00	132.00	04/24/2026	
3535	CENTER FOR INTERNET SECU	INV-260402-00	2026 ANTIVIRUS	04/24/2026	66.00	66.00	04/24/2026	
3535	CENTER FOR INTERNET SECU	INV-260402-00	2026 ANTIVIRUS	04/24/2026	924.00	924.00	04/24/2026	
516	CINTAS CORPORATION	5328914705	FIRST AID RESTOCK	04/10/2026	316.71	316.71	04/17/2026	
519	CISEWSKI BRANDON	Boots 2026	SAFETY SHOES 2026	04/24/2026	200.00	200.00	04/29/2026	
3799	CITY OF MARSHFIELD	33342	INSPECTION STICKERS	04/14/2026	16.35	16.35	04/17/2026	
589	COMPLETE OFFICE OF WI	122947	TAPE DISPENSER	04/22/2026	2.80	2.80	04/24/2026	
698	DASH MEDICAL GLOVES INC	1349472	BLACK MAXX NITRILE GLOVES	04/03/2026	418.95	418.95	04/29/2026	
956	FIRE SAFETY USA INC	256254	DNR GRANT BOOTS	04/14/2026	2,453.00	2,453.00	04/14/2026	
3827	FIREFIGHTER TDC LLC	26-004	THERMAL IMAGER	03/19/2026	360.00	360.00	04/24/2026	
3827	FIREFIGHTER TDC LLC	26-006	CON-SPACE	04/17/2026	500.00	500.00	04/17/2026	
1001	FOX VALLEY TECHNICAL COLL	SPINV034367	TRAINING CONFERENCE	04/27/2026	325.00	325.00	04/29/2026	
3911	GATEWAY TECHNICAL COLLEG	30714	EVIDENCE TECH TRAINING	04/16/2026	350.00	350.00	04/17/2026	
1106	GRAINGER INC	9870566073	SNEEZE GUARD	04/07/2026	63.72	63.72	04/17/2026	
1106	GRAINGER INC	9878136259	DSTROBE LIGHTS FOR BUCKE	04/14/2026	448.44	448.44	04/17/2026	
1106	GRAINGER INC	9886270538	WISE GRIPS	04/20/2026	221.90	221.90	04/29/2026	
1163	HAINZLSPERGER JACOB	CDL 2026	CDL RENEWAL	04/13/2026	40.00	40.00	04/17/2026	
1164	HAKES WELLNESS SOLUTIONS	4349	WELLNESS VISITS	04/02/2026	600.00	600.00	04/17/2026	
1332	JEFFERSON FIRE & SAFETY IN	060909	CREDIT FOR WARRANTY	04/28/2026	444.62-	444.62-	04/29/2026	
1332	JEFFERSON FIRE & SAFETY IN	336766	54 ENGINE 1	02/12/2026	818.56	818.56	04/29/2026	
3909	JRS DIRTWORKS LLC	347	BRUSH PICKUP	04/26/2026	10,050.00	10,050.00	04/29/2026	
1418	KIESLER POLICE SUPPLY INC	IN279300	4 HOLSTERS	04/07/2026	338.98	338.98	04/17/2026	

Vendor	Vendor Name	Invoice Number	Description	Invoice Date	Net Invoice Amount	Amount Paid	Date Paid	Voided
3747	KONRAD MATERIAL SALES LLC	1255927	BAGGED COLD PATCH	04/09/2026	6,740.43	6,740.43	04/17/2026	
1509	LAKE AND POND SOLUTIONS L	21486	CROSSROADS POND MAINT	04/21/2026	1,551.68	1,551.68	04/24/2026	
3914	LAUREN DAILEY	42226	PD WEEK COOKIES	04/23/2026	125.00	125.00	04/24/2026	
1551	LEN DUDAS MOTORS	63779	SQUAD WIRE HARNESS REPAI	04/24/2026	464.64	464.64	04/29/2026	
3917	LORI ROUSSEAU	6/9/26 LPR RE	LPR REFUND	04/28/2026	40.00	40.00	04/29/2026	
3917	LORI ROUSSEAU	6/9/26 LPR RE	SALES TAX REFUND	04/28/2026	2.20	2.20	04/29/2026	
1622	MADA CUSTOM APPAREL & SP	92293	BENCH SPONSORSHIP BLANK	04/07/2026	125.00	125.00	04/17/2026	
1692	MENARDS INC	39506	BREAKER COVER FOR MB GEN	04/07/2026	2.99	2.99	04/17/2026	
1692	MENARDS INC	39567	FENCE POSTS	04/08/2026	124.85	124.85	04/17/2026	
1692	MENARDS INC	39676	FENCE REPAIRS	04/10/2026	67.40	67.40	04/17/2026	
1692	MENARDS INC	39693	PLUMBING PARTS EASLAN WE	04/10/2026	17.07	17.07	04/17/2026	
1692	MENARDS INC	39840	GLUE TO FASTEN BENCH PLAQ	04/13/2026	27.42	27.42	04/24/2026	
1692	MENARDS INC	39892	SOAP DISPENSER BATTERIES	04/14/2026	87.39	87.39	04/24/2026	
1692	MENARDS INC	39913	PAINT FOR BASEBALL FIELD M	04/14/2026	20.82	20.82	04/24/2026	
1692	MENARDS INC	39947	STAINLESS STEEL SCREWS	04/15/2026	11.76	11.76	04/24/2026	
1692	MENARDS INC	39977	DRAIN PLUG	04/15/2026	8.88	8.88	04/24/2026	
1692	MENARDS INC	399908	BATTERIES FOR SOAP DISPEN	04/14/2026	48.98	48.98	04/24/2026	
1692	MENARDS INC	40076	ELECTRICAL SUPPLIES IBER	04/17/2026	25.19	25.19	04/24/2026	
1692	MENARDS INC	40209	SHOVELS	04/20/2026	337.50	337.50	04/29/2026	
1692	MENARDS INC	40459	SMALL SHELTER ELECTRICAL	04/24/2026	75.18	75.18	04/29/2026	
1775	MONROE TRUCK EQUIPMENT I	444635	STROBE LIGHTS FOR TRUCK 1	04/14/2026	1,191.92	1,191.92	04/17/2026	
1796	MUNICIPAL TREASURERS ASS	6922	2026 DUES	04/16/2026	70.00	70.00	04/17/2026	
1878	NORTHEAST WI TECHNICAL C	CINV_007584	STEEL EVOC INSTRUCTOR	04/07/2026	495.00	495.00	04/17/2026	
1942	OSHKOSH FIRE & POLICE EQUI	199556	SCBA BRACKET	03/20/2026	438.85	438.85	04/24/2026	
1942	OSHKOSH FIRE & POLICE EQUI	199728	NEW Q SIREN MOTOR	04/17/2026	967.74	967.74	04/24/2026	
2082	POINT HEATING & COOLING	489173	BOILER REPAIRS	04/14/2026	596.43	596.43	04/24/2026	
2082	POINT HEATING & COOLING	489208	TROUBLESHOOT BOILER ISSU	04/14/2026	150.00	150.00	04/24/2026	
2088	POINT TROPHY	041726ACC	ACCT. TAGS	04/23/2026	10.50	10.50	04/24/2026	
2148	PORTAGE COUNTY TREASURE	DOGS 12.2.25-	4027-4736	04/16/2026	9,080.00	9,080.00	04/17/2026	
2262	REINDERS INC	2451276	WATER PIPE REPAIRS EASLAN	04/10/2026	37.69	37.69	04/17/2026	
2399	SCHIERL TIRE & SERVICE CEN	4046275	SKID LOADER TRAILER TIRES	04/17/2026	653.84	653.84	04/24/2026	
2411	SCOTTS PORTABLE TOILETS	24877	YARD WASTE SITE PORTABLE	04/06/2026	80.00	80.00	04/17/2026	
2450	SHERWIN WILLIAMS COMPANY	087961344204	PAINT FOR SHELTERS	04/28/2026	541.50	541.50	04/29/2026	
3424	SOLARUS	31842184	PACAWA INTERNET	04/16/2026	80.54	80.54	04/17/2026	
2584	STEVENS POINT AUTO CENTE	PWG40831-1	TRUCK #15 FUEL TANK STRAP	04/22/2026	12.49-	12.49-	04/24/2026	
2650	SYMBOL ARTS	0559319	APPREC. WEEK GIFTS	03/05/2026	258.75	258.75	04/24/2026	
2810	TYLER TECHNOLOGIES	060-117554	MARCH	04/22/2026	5,409.12	5,409.12	04/24/2026	
2814	ULINE	206354727	SHOP TOWEL ROLLS	04/06/2026	590.58	590.58	04/17/2026	
2822	UNIFORM SHOPPE OF GREEN	15567	SCHLICE SHIRTS	04/08/2026	374.80	374.80	04/17/2026	
2822	UNIFORM SHOPPE OF GREEN	15571	BEYERS SHIRT AND GLOVES	04/08/2026	156.90	156.90	04/17/2026	
2827	UNITED HEALTHCARE	316920047734	HEALTH INS PREMIUM MAY	04/28/2026	93,541.59	93,541.59	04/29/2026	
2827	UNITED HEALTHCARE	316922714546	APRIL 2026 HEALTH INSURANC	04/28/2026	93,541.59	93,541.59	04/29/2026	
2841	US BANK - VILLAGE VISA CHAR	MARCH 2026	DUNHAMS	04/17/2026	25.30	25.30	04/24/2026	
2841	US BANK - VILLAGE VISA CHAR	MARCH 2026	DOMINOS	04/17/2026	61.57	61.57	04/24/2026	
2841	US BANK - VILLAGE VISA CHAR	MARCH 2026	PURCHASE PROTECTION	04/17/2026	73.50	73.50	04/24/2026	
2841	US BANK - VILLAGE VISA CHAR	MARCH 2026	FIRENUGGETS INC	04/17/2026	700.00	700.00	04/24/2026	
2841	US BANK - VILLAGE VISA CHAR	MARCH 2026	BIRD CITY WI	04/17/2026	175.00	175.00	04/24/2026	
2841	US BANK - VILLAGE VISA CHAR	MARCH 2026	METRO MARKET	04/17/2026	55.95	55.95	04/24/2026	
2841	US BANK - VILLAGE VISA CHAR	MARCH 2026	AMAZON	04/17/2026	94.04	94.04	04/24/2026	
2841	US BANK - VILLAGE VISA CHAR	MARCH 2026	AMAZON	04/17/2026	163.74	163.74	04/24/2026	
2841	US BANK - VILLAGE VISA CHAR	MARCH 2026	CITY OF APPLETON PARK	04/17/2026	6.00	6.00	04/24/2026	
2841	US BANK - VILLAGE VISA CHAR	MARCH 2026	METRO MARKET	04/17/2026	15.47	15.47	04/24/2026	
2841	US BANK - VILLAGE VISA CHAR	MARCH 2026	AMAZON	04/17/2026	13.29	13.29	04/24/2026	
2841	US BANK - VILLAGE VISA CHAR	MARCH 2026	AMAZON	04/17/2026	11.57	11.57	04/24/2026	
2841	US BANK - VILLAGE VISA CHAR	MARCH 2026	FESTIVAL FOODS	04/17/2026	59.99	59.99	04/24/2026	
2841	US BANK - VILLAGE VISA CHAR	MARCH 2026	METAL PROMOTIONS	04/17/2026	1,915.00	1,915.00	04/24/2026	
2841	US BANK - VILLAGE VISA CHAR	MARCH 2026	COMFORT SUITES	04/17/2026	101.00	101.00	04/24/2026	

Vendor	Vendor Name	Invoice Number	Description	Invoice Date	Net Invoice Amount	Amount Paid	Date Paid	Voided
2841	US BANK - VILLAGE VISA CHAR	MARCH 2026	GREEN BAY FOP	04/17/2026	60.00	60.00	04/24/2026	
2841	US BANK - VILLAGE VISA CHAR	MARCH 2026	BRONCO BILLYS SALOON	04/17/2026	46.31	46.31	04/24/2026	
2841	US BANK - VILLAGE VISA CHAR	MARCH 2026	KWIK TRIP	04/17/2026	6.62	6.62	04/24/2026	
2841	US BANK - VILLAGE VISA CHAR	MARCH 2026	CHICK-FIL-A	04/17/2026	10.43	10.43	04/24/2026	
2841	US BANK - VILLAGE VISA CHAR	MARCH 2026	IIMC	04/17/2026	135.00	135.00	04/24/2026	
2841	US BANK - VILLAGE VISA CHAR	MARCH 2026	RECONYX	04/17/2026	10.00	10.00	04/24/2026	
2841	US BANK - VILLAGE VISA CHAR	MARCH 2026	AMAZON	04/17/2026	103.96	103.96	04/24/2026	
2841	US BANK - VILLAGE VISA CHAR	MARCH 2026	AMAZON	04/17/2026	29.94	29.94	04/24/2026	
2841	US BANK - VILLAGE VISA CHAR	MARCH 2026	AMAZON	04/17/2026	89.68	89.68	04/24/2026	
2841	US BANK - VILLAGE VISA CHAR	MARCH 2026	COMFORT SUITES	04/17/2026	101.00	101.00	04/24/2026	
2841	US BANK - VILLAGE VISA CHAR	MARCH 2026	COMFORT SUITES	04/17/2026	101.00	101.00	04/24/2026	
2841	US BANK - VILLAGE VISA CHAR	MARCH 2026	AMAZON	04/17/2026	25.74	25.74	04/24/2026	
2841	US BANK - VILLAGE VISA CHAR	MARCH 2026	AMAZON	04/17/2026	63.88	63.88	04/24/2026	
2841	US BANK - VILLAGE VISA CHAR	MARCH 2026	B&H PHOTO	04/17/2026	199.99	199.99	04/24/2026	
2841	US BANK - VILLAGE VISA CHAR	MARCH 2026	B&H PHOTO	04/17/2026	779.99	779.99	04/24/2026	
2841	US BANK - VILLAGE VISA CHAR	MARCH 2026	NEWEGG MARKETPLACE	04/17/2026	310.74	310.74	04/24/2026	
2841	US BANK - VILLAGE VISA CHAR	MARCH 2026	DIDIS SUPPER CLUB	04/17/2026	24.47	24.47	04/24/2026	
2841	US BANK - VILLAGE VISA CHAR	MARCH 2026	INGELSIDE HOTEL	04/17/2026	318.00	318.00	04/24/2026	
2841	US BANK - VILLAGE VISA CHAR	MARCH 2026	GREEN BAY FOP	04/17/2026	60.00	60.00	04/24/2026	
2841	US BANK - VILLAGE VISA CHAR	MARCH 2026	HANDCUFF BATON	04/17/2026	131.20	131.20	04/24/2026	
2841	US BANK - VILLAGE VISA CHAR	MARCH 2026	SHIELD ARMS	04/17/2026	258.00	258.00	04/24/2026	
2841	US BANK - VILLAGE VISA CHAR	MARCH 2026	KWIK TRIP	04/17/2026	27.41	27.41	04/24/2026	
2841	US BANK - VILLAGE VISA CHAR	MARCH 2026	DIDIS SUPPER CLUB	04/17/2026	20.14	20.14	04/24/2026	
2841	US BANK - VILLAGE VISA CHAR	MARCH 2026	METRO MARKET	04/17/2026	28.83	28.83	04/24/2026	
2841	US BANK - VILLAGE VISA CHAR	MARCH 2026	JIMMY JOHNS	04/17/2026	59.52	59.52	04/24/2026	
2841	US BANK - VILLAGE VISA CHAR	MARCH 2026	5GUYS	04/17/2026	20.55	20.55	04/24/2026	
2841	US BANK - VILLAGE VISA CHAR	MARCH 2026	TACO JOHNS	04/17/2026	14.00	14.00	04/24/2026	
2841	US BANK - VILLAGE VISA CHAR	MARCH 2026	BUFFALO WILD WINGS	04/17/2026	18.81	18.81	04/24/2026	
2841	US BANK - VILLAGE VISA CHAR	MARCH 2026	COMFORT INN	04/17/2026	431.43	431.43	04/24/2026	
2841	US BANK - VILLAGE VISA CHAR	MARCH 2026	KWIK TRIP	04/17/2026	11.03	11.03	04/24/2026	
2841	US BANK - VILLAGE VISA CHAR	MARCH 2026	DIDIS SUPPER CLUB	04/17/2026	31.77	31.77	04/24/2026	
2841	US BANK - VILLAGE VISA CHAR	MARCH 2026	DIDIS SUPPER CLUB	04/17/2026	22.47	22.47	04/24/2026	
2841	US BANK - VILLAGE VISA CHAR	MARCH 2026	CHICK-FIL-A	04/17/2026	14.06	14.06	04/24/2026	
2841	US BANK - VILLAGE VISA CHAR	MARCH 2026	MOD PIZZA	04/17/2026	17.41	17.41	04/24/2026	
2841	US BANK - VILLAGE VISA CHAR	MARCH 2026	KWIK TRIP	04/17/2026	8.04	8.04	04/24/2026	
2841	US BANK - VILLAGE VISA CHAR	MARCH 2026	KWIK TRIP	04/17/2026	13.64	13.64	04/24/2026	
2841	US BANK - VILLAGE VISA CHAR	MARCH 2026	AMAZON	04/17/2026	27.98	27.98	04/24/2026	
2841	US BANK - VILLAGE VISA CHAR	MARCH 2026	AMAZON	04/17/2026	38.58	38.58	04/24/2026	
2841	US BANK - VILLAGE VISA CHAR	MARCH 2026	AMAZON	04/17/2026	43.97	43.97	04/24/2026	
2841	US BANK - VILLAGE VISA CHAR	MARCH 2026	AMAZON	04/17/2026	6.69	6.69	04/24/2026	
2841	US BANK - VILLAGE VISA CHAR	MARCH 2026	AMAZON	04/17/2026	40.57	40.57	04/24/2026	
2841	US BANK - VILLAGE VISA CHAR	MARCH 2026	AMAZON	04/17/2026	18.39	18.39	04/24/2026	
2841	US BANK - VILLAGE VISA CHAR	MARCH 2026	AMAZON	04/17/2026	72.77	72.77	04/24/2026	
2841	US BANK - VILLAGE VISA CHAR	MARCH 2026	METRO MARKET	04/17/2026	18.44	18.44	04/24/2026	
2841	US BANK - VILLAGE VISA CHAR	MARCH 2026	PANERA	04/17/2026	63.29	63.29	04/24/2026	
2841	US BANK - VILLAGE VISA CHAR	MARCH 2026	AMAZON	04/17/2026	9.58	9.58	04/24/2026	
2841	US BANK - VILLAGE VISA CHAR	MARCH 2026	AMAZON	04/17/2026	71.24	71.24	04/24/2026	
2841	US BANK - VILLAGE VISA CHAR	MARCH 2026	AMAZON	04/17/2026	6.68	6.68	04/24/2026	
2841	US BANK - VILLAGE VISA CHAR	MARCH 2026	NATL REGISTRY EMT	04/17/2026	32.00	32.00	04/24/2026	
2841	US BANK - VILLAGE VISA CHAR	MARCH 2026	AMAZON	04/17/2026	53.94	53.94	04/24/2026	
2841	US BANK - VILLAGE VISA CHAR	MARCH 2026	MOD PIZZA	04/17/2026	20.50	20.50	04/24/2026	
2841	US BANK - VILLAGE VISA CHAR	MARCH 2026	KWIK TRIP	04/17/2026	8.04	8.04	04/24/2026	
2841	US BANK - VILLAGE VISA CHAR	MARCH 2026	KWIK TRIP	04/17/2026	8.79	8.79	04/24/2026	
2841	US BANK - VILLAGE VISA CHAR	MARCH 2026	GREEN BAY FOP	04/17/2026	60.00	60.00	04/24/2026	
2841	US BANK - VILLAGE VISA CHAR	MARCH 2026	APWA	04/17/2026	42.00	42.00	04/24/2026	
2841	US BANK - VILLAGE VISA CHAR	MARCH 2026	THUNDER BAY GRILLE	04/17/2026	61.20	61.20	04/24/2026	
2841	US BANK - VILLAGE VISA CHAR	MARCH 2026	HILTON STARBUCKS	04/17/2026	10.97	10.97	04/24/2026	

Vendor	Vendor Name	Invoice Number	Description	Invoice Date	Net Invoice Amount	Amount Paid	Date Paid	Voided
2841	US BANK - VILLAGE VISA CHAR	MARCH 2026	HILTON CLUBHOUSE KITCHEN	04/17/2026	10.31	10.31	04/24/2026	
2841	US BANK - VILLAGE VISA CHAR	MARCH 2026	HILTON APPLETON	04/17/2026	404.00	404.00	04/24/2026	
2841	US BANK - VILLAGE VISA CHAR	MARCH 2026	DIDIS SUPPER CLUB	04/17/2026	28.93	28.93	04/24/2026	
2841	US BANK - VILLAGE VISA CHAR	MARCH 2026	DIDIS SUPPER CLUB	04/17/2026	27.18	27.18	04/24/2026	
2841	US BANK - VILLAGE VISA CHAR	MARCH 2026	CHICK-FIL-A	04/17/2026	11.22	11.22	04/24/2026	
2841	US BANK - VILLAGE VISA CHAR	MARCH 2026	HUHOT MONGOLIAN	04/17/2026	28.73	28.73	04/24/2026	
2841	US BANK - VILLAGE VISA CHAR	MARCH 2026	CHICK-FIL-A	04/17/2026	13.59	13.59	04/24/2026	
2841	US BANK - VILLAGE VISA CHAR	MARCH 2026	CITY OF APPLETON PARK	04/17/2026	12.00	12.00	04/24/2026	
2841	US BANK - VILLAGE VISA CHAR	MARCH 2026	HILTON STARBUCKS	04/17/2026	13.16	13.16	04/24/2026	
2841	US BANK - VILLAGE VISA CHAR	MARCH 2026	CITY OF APPLETON PARK	04/17/2026	6.00	6.00	04/24/2026	
2841	US BANK - VILLAGE VISA CHAR	MARCH 2026	CITY OF APPLETON PARK	04/17/2026	6.00	6.00	04/24/2026	
2841	US BANK - VILLAGE VISA CHAR	MARCH 2026	HILTON STARBUCKS	04/17/2026	10.97	10.97	04/24/2026	
2841	US BANK - VILLAGE VISA CHAR	MARCH 2026	HILTON APPLETON	04/17/2026	528.99	528.99	04/24/2026	
2841	US BANK - VILLAGE VISA CHAR	MARCH 2026	JIMMY JOHNS	04/17/2026	14.13	14.13	04/24/2026	
2841	US BANK - VILLAGE VISA CHAR	MARCH 2026	5GUYS	04/17/2026	19.40	19.40	04/24/2026	
2841	US BANK - VILLAGE VISA CHAR	MARCH 2026	5GUYS	04/17/2026	7.37	7.37	04/24/2026	
2841	US BANK - VILLAGE VISA CHAR	MARCH 2026	CITY OF APPLETON PARK	04/17/2026	6.00	6.00	04/24/2026	
2841	US BANK - VILLAGE VISA CHAR	MARCH 2026	HILTON STARBUCKS	04/17/2026	9.62	9.62	04/24/2026	
2841	US BANK - VILLAGE VISA CHAR	MARCH 2026	SALS PIZZA	04/17/2026	6.73	6.73	04/24/2026	
2841	US BANK - VILLAGE VISA CHAR	MARCH 2026	CITY OF APPLETON PARK	04/17/2026	12.00	12.00	04/24/2026	
2841	US BANK - VILLAGE VISA CHAR	MARCH 2026	JIMMY JOHNS	04/17/2026	11.81	11.81	04/24/2026	
2841	US BANK - VILLAGE VISA CHAR	MARCH 2026	HILTON CLUBHOUSE KITCHEN	04/17/2026	50.48	50.48	04/24/2026	
2843	US CELLULAR	803174316	APRIL PHONES	04/28/2026	167.71	167.71	04/29/2026	
3024	WELD RILEY SC	42	MARCH 26 LEGAL	04/15/2026	1,900.00	1,900.00	04/24/2026	
3024	WELD RILEY SC	42	MARCH 26 LEGAL	04/15/2026	40.00	40.00	04/24/2026	
3540	WHITE CAP	50035809215	BELT TOOL HOOK	03/12/2026	9.00	9.00	04/17/2026	
3540	WHITE CAP	50036269137	AIR MONITOR FILTERS	04/13/2026	124.50	124.50	04/17/2026	
3540	WHITE CAP	50036279984	WORK GLOVES	04/13/2026	75.80	75.80	04/17/2026	
3540	WHITE CAP	50036476003	CORDLESS GREASE GUN	04/21/2026	331.10	331.10	04/24/2026	
3540	WHITE CAP	50036522749	METAL SAFETY GAS CANS	04/23/2026	214.18	214.18	04/24/2026	
3107	WI DEPT OF JUSTICE - TIME	455TIME-0000	TIME ACCESS	04/15/2026	447.75	447.75	04/17/2026	
3111	WI DEPT OF JUSTICE-CRIME IN	2SCdND86	PERSONNEL/HIRING	04/15/2026	7.00	7.00	04/24/2026	
3127	WI DEPT OF TRANSPORTATION	1G9ER6NA8T	WI DEPT. OF TRANSPORTATIO	04/16/2026	231.50	231.50	04/17/2026	
3208	WINTER EQUIPMENT COMPAN	IV68713	UNDERBODY BLADES	04/17/2026	14,000.00	14,000.00	04/24/2026	
3208	WINTER EQUIPMENT COMPAN	IV68713	PLOW BLADES	04/17/2026	11,615.80	11,615.80	04/24/2026	
3305	ZBLEWSKI BROS LLC	36878	2026 SPRING BUSH CLEANUP	04/28/2026	5,980.00	5,980.00	04/29/2026	
Total 100:					294,423.06	294,423.06		
230								
1622	MADA CUSTOM APPAREL & SP	92359	2026 SAFETY SHIRT ORDER	04/21/2026	200.00	200.00	04/24/2026	
Total 230:					200.00	200.00		
250								
1509	LAKE AND POND SOLUTIONS L	21485	FOUNTAIN REPAIR AND INSTAL	04/20/2026	1,567.96	1,567.96	04/24/2026	
3908	SPARTAN TURF PRODUCTS LL	6088454-00	INFIELD GROOMER ATTACHME	04/16/2026	1,256.58	1,256.58	04/17/2026	
3436	WAUSAU TILE INC.	736207	CORNHOLE	04/16/2026	1,450.00	1,450.00	04/17/2026	
Total 250:					4,274.54	4,274.54		
400								
373	BROOKS TRACTOR INC	C00225	2026 LOADER	04/24/2026	166,500.00	166,500.00	04/28/2026	
Total 400:					166,500.00	166,500.00		

Vendor	Vendor Name	Invoice Number	Description	Invoice Date	Net Invoice Amount	Amount Paid	Date Paid	Voided
500								
195	AT&T- NEW PHONES 831-001-20	5574824118	APRIL	04/17/2026	15.49	15.49	04/24/2026	
3535	CENTER FOR INTERNET SECU	INV-260402-00	2026 ANTIVIRUS	04/24/2026	396.00	396.00	04/24/2026	
3604	GUNNING, ZACKARY	25612	UNIFORM REIMBURSEMENT	04/27/2026	234.00	234.00	04/29/2026	
1692	MENARDS INC	39517	STATION SUPPLIES	04/13/2026	42.88	42.88	04/17/2026	
2841	US BANK - VILLAGE VISA CHAR	MARCH 2026	AMAZON	04/17/2026	31.84	31.84	04/24/2026	
2841	US BANK - VILLAGE VISA CHAR	MARCH 2026	YOUTUBE TV	04/17/2026	82.99	82.99	04/24/2026	
2841	US BANK - VILLAGE VISA CHAR	MARCH 2026	WALMART	04/17/2026	81.82	81.82	04/24/2026	
2841	US BANK - VILLAGE VISA CHAR	MARCH 2026	USPS	04/17/2026	22.30	22.30	04/24/2026	
3024	WELD RILEY SC	42	MARCH 26 LEGAL	04/15/2026	900.00	900.00	04/24/2026	
Total 500:					1,807.32	1,807.32		
521								
285	BELCO VEHICLE SOLUTIONS L	11484	BLAZER VEHICLE BUILD	04/29/2026	5,278.15	5,278.15	04/29/2026	
Total 521:					5,278.15	5,278.15		
600								
195	AT&T- NEW PHONES 831-001-20	5574824118	APRIL	04/17/2026	162.68	162.68	04/24/2026	
392	BUSHMAN ELECTRIC CRANE &	38348	AIRLINE LS METER POLE REPL	04/28/2026	1,164.75	1,164.75	04/29/2026	
446	CELLCOM	983483	CELLCOM	04/23/2026	124.02	124.02	04/29/2026	
3535	CENTER FOR INTERNET SECU	INV-260402-00	2026 ANTIVIRUS	04/24/2026	726.00	726.00	04/24/2026	
3535	CENTER FOR INTERNET SECU	INV-260402-00	2026 ANTIVIRUS	04/24/2026	66.00	66.00	04/24/2026	
615	CORE & MAIN LP	Y847087	SANITARY SEWER MANHOLE C	04/27/2026	5,225.00	5,225.00	04/29/2026	
775	DONOHUE & ASSOCIATES INC	14598-11	DONOHUE COLLECTION SYST	04/24/2026	4,394.00	4,394.00	04/29/2026	
1621	MACQUEEN EQUIPMENT	W09326	MOBILE SEVICE FOR VAC TRU	04/14/2026	2,434.24	2,434.24	04/17/2026	
1692	MENARDS INC	40281	MAINT SUPPLIES	04/21/2026	29.39	29.39	04/24/2026	
1692	MENARDS INC	40476	TOOLS AND MAINT SUPPLIES	04/24/2026	101.44	101.44	04/29/2026	
1790	MULCAHY SHAW WATER INC	327167	ULTRASONIC INFLUENT FLOW	12/02/2025	3,500.00	3,500.00	04/24/2026	
1790	MULCAHY SHAW WATER INC	327167	ULTRASONIC INFLUENT FLOW	12/02/2025	400.00	400.00	04/24/2026	
1790	MULCAHY SHAW WATER INC	327519	BOERGER PUMP PARTS	04/24/2026	983.74	983.74	04/29/2026	
3371	O'REILLY AUTO	6597-191536	HYDRAULIC OIL	04/13/2026	149.98	149.98	04/17/2026	
3710	RIVER AUTOMATION INC	I26084	PLC TROUBLESHOOTING AND	04/20/2026	1,215.00	1,215.00	04/24/2026	
3424	SOLARUS	11903956	WWTF PHONE SERVICE	05/01/2026	22.39	22.39	04/29/2026	
2500	SOLENIIS LLC	135565321	K144 POLYMER	04/20/2026	10,273.63	10,273.63	04/24/2026	
2584	STEVENS POINT AUTO CENTE	PWG40831-1	LIGHTNING TRK INSPECTION	04/22/2026	25.90	25.90	04/24/2026	
2841	US BANK - VILLAGE VISA CHAR	MARCH 2026	AMAZON	04/17/2026	208.99	208.99	04/24/2026	
2841	US BANK - VILLAGE VISA CHAR	MARCH 2026	JIMMY JOHNS	04/17/2026	59.52	59.52	04/24/2026	
2841	US BANK - VILLAGE VISA CHAR	MARCH 2026	EBAY	04/17/2026	34.00	34.00	04/24/2026	
2841	US BANK - VILLAGE VISA CHAR	MARCH 2026	METRO MARKET	04/17/2026	28.84	28.84	04/24/2026	
2841	US BANK - VILLAGE VISA CHAR	MARCH 2026	AMAZON WEB	04/17/2026	.52	.52	04/24/2026	
2841	US BANK - VILLAGE VISA CHAR	MARCH 2026	ORINGS AND MORE	04/17/2026	9.15	9.15	04/24/2026	
2841	US BANK - VILLAGE VISA CHAR	MARCH 2026	DNR	04/17/2026	.90	.90	04/24/2026	
2841	US BANK - VILLAGE VISA CHAR	MARCH 2026	DNR	04/17/2026	45.00	45.00	04/24/2026	
2841	US BANK - VILLAGE VISA CHAR	MARCH 2026	AMAZON	04/17/2026	9.99	9.99	04/24/2026	
2841	US BANK - VILLAGE VISA CHAR	MARCH 2026	WVWA	04/17/2026	93.15	93.15	04/24/2026	
2841	US BANK - VILLAGE VISA CHAR	MARCH 2026	AMAZON	04/17/2026	201.29	201.29	04/24/2026	
2841	US BANK - VILLAGE VISA CHAR	MARCH 2026	AMAZON	04/17/2026	196.98	196.98	04/24/2026	
2843	US CELLULAR	803174316	APRIL PHONES	04/28/2026	82.23	82.23	04/29/2026	
2856	USA BLUEBOOK	INV01029465	LAB TESTING SUPPLIES	04/24/2026	1,452.24	1,452.24	04/29/2026	
3540	WHITE CAP	50036489121	LADTECH MH ADJUSTMENT RI	04/22/2026	10,277.47	10,277.47	04/24/2026	
3142	WI ENVIRONMENTAL IMPROVE	22092	4720-03 PRINCIPAL	04/28/2026	354,080.92	354,080.92	04/29/2026	
3142	WI ENVIRONMENTAL IMPROVE	22092	4720-03 INTEREST	04/28/2026	26,400.98	26,400.98	04/29/2026	
Total 600:					424,180.33	424,180.33		

Vendor	Vendor Name	Invoice Number	Description	Invoice Date	Net Invoice Amount	Amount Paid	Date Paid	Voided
700								
195	AT&T- NEW PHONES 831-001-20	5574824118	APRIL	04/17/2026	108.45	108.45	04/24/2026	
269	BATTERIES PLUS	P91393348	BATTERIES PLUS	04/28/2026	16.65	16.65	04/29/2026	
317	BLACKBURN MANUFACTURING	IN0028927	MARKING PAINT	04/15/2026	609.57	609.57	04/17/2026	
3782	C4 METALS	INV-0000032	RACKING	03/09/2026	1,400.00	1,400.00	04/24/2026	
3648	CBS SQUARED INC	17441	WELL 1 GENERATOR	04/10/2026	4,244.20	4,244.20	04/17/2026	
443	CDW GOVERNMENT INC	AI7H26J	CAT6 CABLE	04/01/2026	347.07	347.07	04/17/2026	
446	CELLCOM	980822	CELLPHONES	04/29/2026	583.37	583.37	04/29/2026	
3535	CENTER FOR INTERNET SECU	INV-260402-00	2026 ANTIVIRUS	04/24/2026	660.00	660.00	04/24/2026	
3535	CENTER FOR INTERNET SECU	INV-260402-00	2026 ANTIVIRUS	04/24/2026	66.00	66.00	04/24/2026	
610	COOPER OIL COMPANY INC	350675	COOPER OIL COMPANY INC	04/20/2026	363.95	363.95	04/24/2026	
663	CTW CORPORATION	42618	CTW CORPORATION	04/17/2026	22,473.00	22,473.00	04/24/2026	
682	DAKOTA SUPPLY GROUP	S105608926.0	UNIT HEATER HANGER	04/20/2026	1,175.91	1,175.91	04/24/2026	
907	FAHRNER EXCAVATING INC	E-12125	WATER SERVICES	04/20/2026	3,903.00	3,903.00	04/29/2026	
936	FERGUSON WATERWORKS #14	0471286	METER FLANGE/GASKET	04/13/2026	1,956.77	1,956.77	04/17/2026	
936	FERGUSON WATERWORKS #14	0471286-1	METAL DETECTOR	04/13/2026	1,175.00	1,175.00	04/17/2026	
936	FERGUSON WATERWORKS #14	0472207	VALVE BOX PARTS	04/17/2026	3,869.39	3,869.39	04/24/2026	
3848	GAYLORD, COLTEN	CG_0421_26	SAFETY SHOES	04/23/2026	200.00	200.00	04/24/2026	
1129	GREEN THUMB SPRINKLERS &	6405	TREES	03/29/2026	796.00	796.00	04/29/2026	
1251	HYDROCORP INC	CI-11357	HYDROCORP INC	02/27/2026	1,165.00	1,165.00	04/24/2026	
1320	JAKUBEK CASEY	CJ_0409_2026	UNIFORM PANTS	04/16/2026	400.90	400.90	04/17/2026	
1622	MADA CUSTOM APPAREL & SP	979.55	SAFETY APARREL	04/22/2026	979.55	979.55	04/24/2026	
1652	MARTELLE WATER TREATMEN	31412	MARTELLE WATER TREATMEN	04/22/2026	1,601.33	1,601.33	04/29/2026	
1692	MENARDS INC	39577	MARKING PAINT	04/08/2026	14.98	14.98	04/17/2026	
1692	MENARDS INC	39807	MARKING PAINT	04/13/2026	14.98	14.98	04/17/2026	
1692	MENARDS INC	39810	CLEANING SUPPLIES	04/13/2026	43.18	43.18	04/17/2026	
1692	MENARDS INC	39883	SERVICE PLUG	04/14/2026	13.99	13.99	04/17/2026	
1692	MENARDS INC	40228	WALL BASE	04/20/2026	238.06	238.06	04/24/2026	
1692	MENARDS INC	40331	BOLLARDS	04/22/2026	38.26	38.26	04/24/2026	
1692	MENARDS INC	40401	SECURITY CAMERA	04/23/2026	187.91	187.91	04/29/2026	
3682	METRON FARNIER LLC	992424855	METERS	04/24/2026	57,259.43	57,259.43	04/29/2026	
3525	MIDSTATE LOCK & SAFE LLC	26-9764	SPARE KEYS	04/28/2026	144.00	144.00	04/29/2026	
3895	N.E.W. COATINGS LLC	8963	FLOOR COATING	04/01/2026	3,496.72	3,496.72	04/24/2026	
2111	POLLARD WATER	0308851	CURB BOX WRENCHES	04/17/2026	848.10	848.10	04/24/2026	
2383	SALOUN, MATT	MS_0421_26	SAFETY SHOES	04/21/2026	200.00	200.00	04/24/2026	
2461	SHORT ELLIOTT HENDRICKSO	506817	CTH R WATERMAIN DESIGN	04/08/2026	2,844.84	2,844.84	04/17/2026	
2633	SUPERIOR CHEMICAL LLC	439292	SILICONE LUBE, FREIGHT	04/13/2026	354.37	354.37	04/17/2026	
2841	US BANK - VILLAGE VISA CHAR	MARCH 2026	AMAZON	04/17/2026	134.25	134.25	04/24/2026	
2841	US BANK - VILLAGE VISA CHAR	MARCH 2026	DNR	04/17/2026	1.80	1.80	04/24/2026	
2841	US BANK - VILLAGE VISA CHAR	MARCH 2026	DNR	04/17/2026	90.00	90.00	04/24/2026	
2841	US BANK - VILLAGE VISA CHAR	MARCH 2026	AMAZON	04/17/2026	301.78	301.78	04/24/2026	
2841	US BANK - VILLAGE VISA CHAR	MARCH 2026	AMAZON	04/17/2026	22.99	22.99	04/24/2026	
2841	US BANK - VILLAGE VISA CHAR	MARCH 2026	METRO MARKET	04/17/2026	28.83	28.83	04/24/2026	
2841	US BANK - VILLAGE VISA CHAR	MARCH 2026	JIMMY JOHNS	04/17/2026	59.52	59.52	04/24/2026	
2841	US BANK - VILLAGE VISA CHAR	MARCH 2026	INDEED	04/17/2026	59.40	59.40	04/24/2026	
3748	VMC LLC	1804	DISK AT&T	04/15/2026	1,000.00	1,000.00	04/17/2026	
3748	VMC LLC	1805	LINCOLN AT&T	04/15/2026	4,500.00	4,500.00	04/17/2026	
3748	VMC LLC	1806	LINCOLN AT&T	04/15/2026	2,500.00	2,500.00	04/17/2026	
3748	VMC LLC	1807	LINCOLN AT&T	04/15/2026	1,800.00	1,800.00	04/17/2026	
3024	WELD RILEY SC	42	MARCH 26 LEGAL	04/15/2026	80.00	80.00	04/24/2026	
3073	WI DNR - OPERATOR CERT	JT_0428_2026	OPERATOR EXAMS	04/28/2026	75.00	75.00	04/29/2026	
3142	WI ENVIRONMENTAL IMPROVE	22092	4882-01 PRINCIPAL	04/28/2026	143,198.53	143,198.53	04/29/2026	
3142	WI ENVIRONMENTAL IMPROVE	22092	4882-01 INTEREST	04/28/2026	22,615.44	22,615.44	04/29/2026	
3245	WISCONSIN RURAL WATER AS	WRWA_0428_	WISCONSIN RURAL WATER AS	04/28/2026	125.00	125.00	04/29/2026	
3245	WISCONSIN RURAL WATER AS	WRWA_428_2	TRAINING	04/28/2026	500.00	500.00	04/29/2026	

Vendor	Vendor Name	Invoice Number	Description	Invoice Date	Net Invoice Amount	Amount Paid	Date Paid	Voided
Total 700:					290,886.47	290,886.47		
810								
3915	BRIAN HOPPERDIETZEL	2026 KWM TIL	MEMORIAL TILES	04/24/2026	664.00	664.00	04/24/2026	
Total 810:					664.00	664.00		
Grand Totals:					1,188,213.87	1,188,213.8		

Vendor	Vendor Name	Invoice Number	Description	Invoice Date	Net Invoice Amount	Amount Paid	Date Paid	Voided
--------	-------------	----------------	-------------	--------------	-----------------------	-------------	-----------	--------

Dated:

Village President: Gary Wolf

Village Board :

Steve Fritz: _____

Tim Durigan: _____

Ross Ballard: _____

Adam Raabe: _____

Al Haga: _____

Al Tessmann: _____

Administrator: Steve Kunst

Vendor	Vendor Name	Invoice Number	Description	Invoice Date	Net Invoice Amount	Amount Paid	Date Paid	Voided
--------	-------------	----------------	-------------	--------------	-----------------------	-------------	-----------	--------

Report Criteria:

Detail report.

Invoices with totals above \$0.00 included.

Paid and unpaid invoices included.

[Report].GL Account Number (3 Characters) = {<>} "200"



VILLAGE OF PLOVER

STAFF MEMO

VILLAGE BOARD

Submitted by: Scott Klemm, Public Works Manager

Date: May 1st, 2026

Subject: Approval of Hoover Ave preventative maintenance

Background: Village of Plover Public Works Department has requested a price quote from Fahrner Asphalt Sealers for crack filling and mastic repairs for Hoover Avenue from CTH HH south to Maple Drive. Due to the wet winter and spring along with the freeze thaws this winter the road is showing significant depreciation and needs some unexpected preventative maintenance to help prolong the life of the current road surface. Project will be funded by Public Works chip seal account and remaining needed balance will come from funds remaining from the 2026 bonding. Staff recommend approval of the contract to Fahrner Asphalt Sealers.

Exhibits to include:

- Exhibit 1: Fahrner Asphalt Sealers proposal

PROPOSAL / CONTRACT

Job. No. _____



Date: April 21, 2026

CORPORATE OFFICE

2800 Mecca Drive • Plover, WI 54467
phone 715.341.2868 • fax 715.341.1054

751 N Bluemound Drive • Appleton, WI 54914
phone 920.759.1008 • fax 920.759.1019

6615 US Highway 12 W • Eau Claire, WI 54703
phone 715.874.6070 • fax 715.874.6717

Pavement Maintenance Contractors

EOE, including disability / vets

914 Commercial Court • Onalaska, WI 54650
phone 608.779.6641 • fax 608.779.6813

316 Raemisch Road • Waunakee, WI 53597
phone 608.849.6466 • fax 608.849.6470

111 Anderson Road • Iron River, MI 49935
phone 906.265.6770 • fax 906.265.5719

2224 Veterans Memorial Pkwy • Saginaw, MI 48601
phone 989.752.9200 • fax 989.752.9205

Contact Name: **Scott Klemm**

Contract Price **\$72,039.73**

PURCHASER: **VILLAGE OF PLOVER**

TELEPHONE: **(715) 345-5257**

ADDRESS:

DESCRIPTION OF PROPERTY:

P.O. BOX 37

Hoover Ave. CF

PLOVER, WI 54467

P.O. BOX 37

PLOVER, WI 54467

1. FAHRNER Asphalt Sealers, L.L.C. (CONTRACTOR) and PURCHASER agree that, CONTRACTOR shall furnish the labor and materials to complete certain construction in accordance with the following specifications:

HOOVER AVE.: CTY. HH (S) TO THE PACAWA PARK CROSSWALK

Blow out and clean cracks with compressed air and heat lance.

Seal cracks with Fed Spec ASTM D 6690 hot rubber asphalt sealant and over-band using squeegee; immediately followed by a single ply of tissue paper or detak to prevent tracking.

Blow out and clean cracks with compressed air and heat lance. Flood area with BCI Flex-Patch to repair as necessary. Cover immediately with 1/8" dried trap rock.

***Included is all traffic control and signage.

***Supply the stone for the larger areas that may need flex patch.

This proposal may be withdrawn if not accepted and received by CONTRACTOR within 15 days of the date above and/ or at any time before performance of the work hereunder upon CONTRACTOR'S determination that the PURCHASER is not creditworthy.

2. If proposal is accepted please sign, retain one copy and forward a copy to our office.

3. The undersigned ("PURCHASER") agrees to pay CONTRACTOR the total price of \$72,039.73 and/or the unit prices specified above for the labor and materials specified above which payment shall be due upon completion of each stage of work.

PURCHASER acknowledges that the specifications, conditions and price quotes specified above are satisfactory and hereby accepted. By my signature herein, I authorize CONTRACTOR to review personal OR business Credit Reports to evaluate financial readiness to pay amounts set forth in this Proposal/Contract.

Acceptance of this Proposal includes acceptance of all the terms and conditions on back.

CONTRACTOR:

Fahrner Asphalt Sealers, LLC: (715) 315-1873

jim.zdroik@fahrnerasphalt.com

PURCHASER:

I have read and understand the terms and conditions on both sides of this contract.

James Zdroik

(PRINT OR TYPE NAME)

(PRINT OR TYPE NAME)

By:

James Zdroik

(CONTRACTOR REPRESENTATIVE)

By:

(PURCHASER AUTHORIZED REPRESENTATIVE)

Date: April 21, 2026

Date of acceptance: _____



VILLAGE OF PLOVER

STAFF MEMO

VILLAGE BOARD

Submitted by: Scott Klemm, Public Works Manager

Date: May 1st, 2026

Subject: Approval of Equipment purchases

Background: Village of Plover Public Works Department is requesting the approval of two pieces of equipment for street maintenance. Mr. Manhole circular manhole/water valve cutter. The purpose of the skid loader attachment is to improve the life of manhole castings and water valves and to prevent future damage from plows hitting the collars along with providing a smoother drive surface. This unit is a three-department purchase with the costs shared equally between Public Works, Water and Wastewater. The second attachment is new MB broom attachment to replace an aging motorized Broce broom and provides for an existing tractor to be more widely utilized throughout the year as a dual-purpose unit. Both purchases are being funded by Public Works fund 532 from the current auction proceeds and Water and Wastewater funding from their accounts. Staff recommend approval of both purchases of equipment.

Exhibits to include:

- Exhibit 1: Mr. Manhole quote
- Exhibit 2: Mr. Mahole specifications
- Exhibit 3: Mr. Manhole Gold series literature
- Exhibit 4: Mr. Manhole water valve literature
- Exhibit 5: Service Motor MB broom quote
- Exhibit 6: MB broom literature



CRITEX LLC.
 125 S Canal St
 Delphos, OH 45833

Estimate

DATE	ESTIMATE #
4/20/2026	861

BILL TO
Scott Klemm Village of Plover 2400 Post Road Plover, WI 54467 United States

SHIP TO
Scott Klemm Village of Plover 2801 Chestnut Drive Plover, WI 54467 United States sklemm@ploverwi.gov 7156455257

Item	Description	Qty	Rate	Amt
K-MM0002	GOLD SERIES SIX SHOOTER CUSTOMER PACKAGE (STANDARD SPEEDPLATE & 2 1/2" AUGER MOTOR) INCLUDES: GOLD SERIES SIX SHOOTER CUTTER, STANDARD SPEEDPLATE, MODEL 40 AUGER DRIVE UNIT (HIGH & LOW FLOW) WITH 2.5" HEX DRIVE, MAGNET/WITH D-RING, SAFETY BAR, QUICK CHANGE GUN, ADDITIONAL PLUG IN TEETH (12), DEBRIS SHIELD, CASTING LIFTER, SPEEDPLATE TRANSPORT HUB	1	\$47,880.00	\$47,880.00
K-MM0325	WATER VALVE REBUILD PACKAGE	1	\$7,225.00	\$7,225.00
A-MM0328	MR. MISTER SILICA CONTROL ASSEMBLY	1	\$2,365.00	\$2,365.00
SUBTOTAL				\$57,470.00
SHIPPING				\$516.00
DISCOUNT				\$0.00
TAX				\$0.00
TOTAL				\$57,986.00

1. Cutter Specifications

- **Cutting Diameter Range:**
 - Standard: **44 in. – 60 in.**
 - With Underslung Arms: **22 in. – 34 in.**
 - With Extension Arm: **Up to 72 in.**
- **Cutting Depth:** Standard **14 in.**, up to **20 in.** with extended blades.
- **Cutting Arms:** Six (6) adjustable arms, diameter adjustable **without tools.**
- **Drive System:** Heavy-duty auger motor with **2.5 in. hex drive**, direct-drive platform (no chain or sprocket).
- **Mounting Plate:** Universal skid steer plate with **12 in. forward offset** for large-diameter cutting.
- **Teeth:** Quick-change, carbide-tipped teeth for asphalt and concrete.
- **Control System:**
 - No tethered electrical control boxes.
 - No electrical junction boxes.
- **Included Components:** All hoses, fittings, and connections required for hydraulic operation.

Gold Series Six Shooter Major Components:

- Main Frame Kit (K-MM0549) – 555 lbs
 - Top Drive 2.5" Kit (K-MM0374) – 129 lbs
 - Six Cutter Arms (P-MM0018) – 210 lbs
 - Six Cutter Blades with Teeth (A-MM0360) – 147 lbs
 - Standard Guide Shaft (K-MM0510) – 42.5 lbs
 - Leg Assemblies (A-MM0013) – 96 lbs
 - Bottom Drive Kit (K-MM0370) – 56.5 lbs
 - Transport Hub (K-MM0560) – 9 lbs
- (Full part list with part numbers available upon request.)*

2. Auger Specifications

- **Auger Drive Model:** Heavy Duty Auger Drive Model 40 with **2.5 in. hex output shaft.**
 - **Total Weight (Six Shooter Assembly):** ~1,200 lbs (mechanical lift recommended).
 - **Component Weights:**
 - Auger Drive (Model 40): 485 lbs – mechanical lift
 - Standard Speedplate: 85 lbs – two-person/mechanical
 - Standard Guide Shaft: 42.5 lbs – one-person
 - Extended Guide Shaft (47"): 57 lbs – two-person/mechanical
 - Casting Lifter: 14 lbs – one-person
-

3. Skid Steer Specifications

- **Lifting Capacity:** Minimum **2,500 lbs** rated operating capacity.
 - **Hydraulic Flow:**
 - Minimum: **20 GPM**
 - Optimal: **30–45 GPM high-flow** circuit (faster cutting speeds).
 - **Hydraulic Pressure:** Up to **4,500 PSI**.
 - **Coupler:** Standard skid steer universal quick-attach.
 - **Visibility Advantage:** Skid steer mounting allows operator clear view of work during cutting.
-

4. Operating Specifications

- **Hydraulic Flow Requirements:**
 - Minimum: 20 GPM
 - Maximum: 45 GPM
- **Hydraulic Pressure:** Up to 4,500 PSI
- **Case Drain Line:** Not required
- **Output Shaft Options:** 2 in. Hex or 2.5 in. Hex

Performance (Flow vs. RPM):

- 20 GPM → ~53 RPM
- 25 GPM → ~67 RPM
- 30 GPM → ~80 RPM
- 35 GPM → ~94 RPM

Performance (Pressure vs. Torque):

- 2,500 PSI → 2,861 ft-lbs
- 3,000 PSI → 3,433 ft-lbs
- 3,500 PSI → 4,005 ft-lbs
- 4,000 PSI → 4,578 ft-lbs

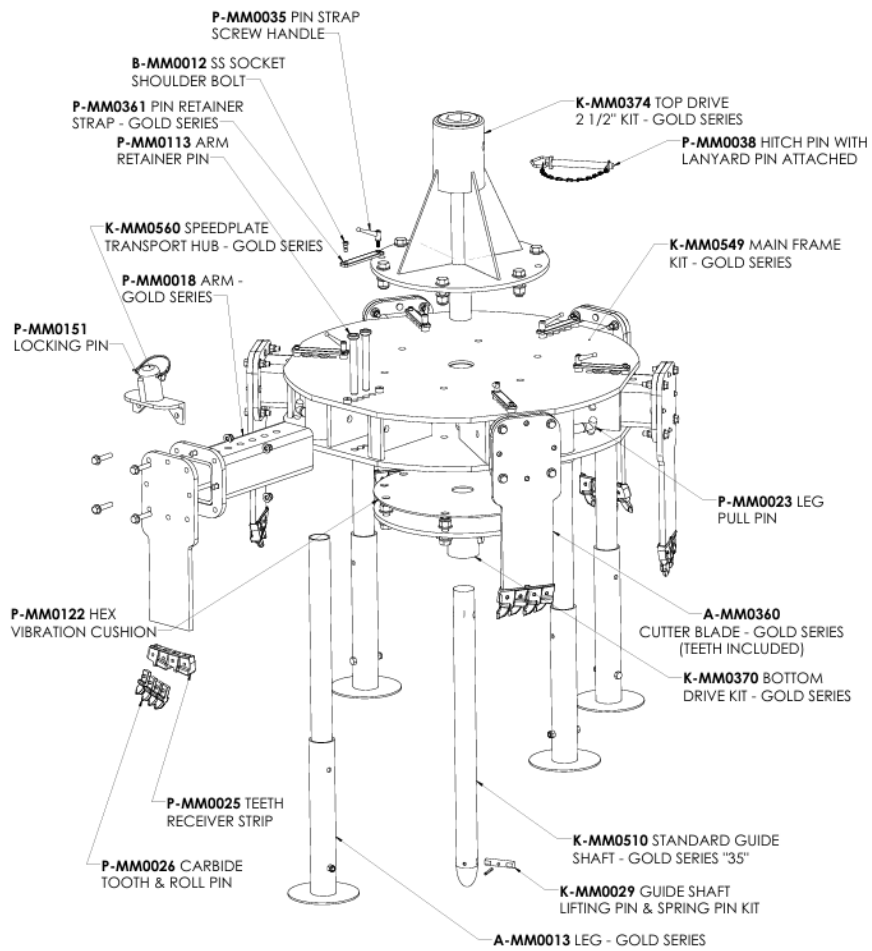

**PROUDLY
MANUFACTURED
IN THE U.S.A.**



Gold Series Six Shooter

**A revolutionary, time-tested product
to remove and replace manholes**



**Uniquely designed to cut out
manhole frames using a round
cut instead of a square**

Fast • Safe • Affordable

**Mr. Manhole's Gold Series Six
Shooter takes the work out of
manhole repair.**

The Gold Series Six Shooter is the latest in manhole repair technology, with no other company in the world offering a similar tool. Uniquely designed to cut out manhole frames using a round cut instead of square, the Six Shooter makes manhole removal and repair smarter, faster, and safer for construction crews.

With the Mr. Manhole system, your crew can cut out manhole frames and the surrounding road in about 10 minutes and finish the job in an hour. In comparison, it takes one to three days to repair a single manhole using the conventional way.

**Specifically crafted for high-volume
manhole repairs with increased power,
speed, and durability**



www.MrManhole.com



Six arms and cutting blades that easily cut through concrete and asphalt!

Why choose Mr. Manhole?

-  **SAVE TIME**
Drastically reduce costly traffic control hours.
-  **SAVE MONEY**
Reduce the amount of equipment required.
-  **IMPROVE CREW MORALE**
Use the latest and most efficient equipment.
-  **REPUTATION FOR EXCELLENCE**
Speed and quality of repairs will quickly be noticed.
-  **PROVEN METHOD**
The world is taking notice of this new standard.



This package is the State of the Art for repairing manholes. It includes everything you need to remove manholes quickly for rebuilding.

- Gold Series Six Shooter
- Heavy Duty Auger Drive Model 40 2.5" Hex Drive
- Standard Speedplate
- Safety Bar
- Casting Lifter Bracket
- Extended Guide Shaft Gold Series 47"
- Debris Shield
- Quick Change Teeth Gun Kit
- Lifting Magnet
- Carbide Tooth and Roll Pin (Bag of 24)

Scan To Learn More About This Cutter.



[mrmanhole](#)



[mrmanhole](#)



[mrmanhole](#)



[mr.manholetool](#)



TOLL FREE 833-242-2221

**PROUDLY
MANUFACTURED
IN THE U.S.A.**



Water Valve Rebuild Package

The solution to smaller diameter repairs is our Water Valve Rebuild Package

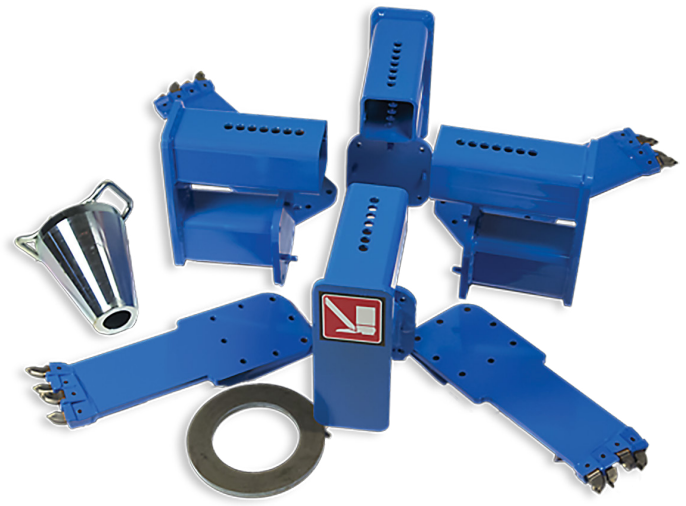

**Easily cut out and
repair water valves**

Fast • Safe • Affordable

If you often repair water valves, the Water Valve Rebuild Package is for you.

The Water Valve Rebuild Package includes:

- ✓ Centering cone — fits in the water valve casting and centers the Mr. Manhole tool while cutting
- ✓ Reducer ring
- ✓ Platinum underslung arms — relocate the cutting blades underneath the cutter for a smaller diameter cut
- ✓ Special reduced diameter cutting blades — these blades cut smaller diameters better and last longer
- ✓ Hardware kit for attaching cutting blades

Using underslung arms, it decrease the diameter of your Mr. Manhole tool to just 28".



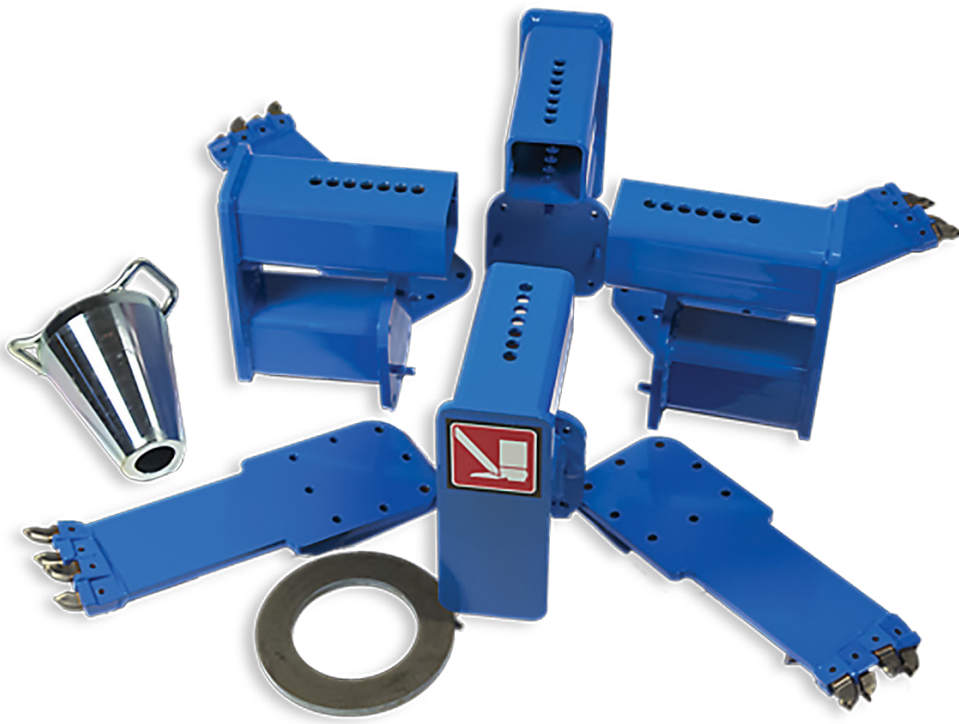

Why choose Mr. Manhole?

- SAVE TIME**
Drastically reduce costly traffic control hours.
- SAVE MONEY**
Reduce the amount of equipment required.
- IMPROVE CREW MORALE**
Use the latest and most efficient equipment.
- REPUTATION FOR EXCELLENCE**
Speed and quality of repairs will quickly be noticed.
- PROVEN METHOD**
The world is taking notice of this new standard.

The solution to smaller diameter repairs is our Water Valve Rebuild Package.

Some crews specialize in more than manhole repair. Many bid water valve repairs. If your crew works to repair and rebuild water valves and other small diameter cuts, you need the Water Valve Repair Package. Using underslung arms, it decreases the diameter of your Mr. Manhole tool to just 28”.

Scan To Learn More About This Package.



- [mrmanhole](#)
- [mrmanhole](#)
- [mrmanhole](#)
- [mr.manholetool](#)

TOLL FREE 833-242-2221



Available Options

- Dirt Deflector
- Electric/Hydraulic Swing
- Independent Hydraulic System (Tractors only)
- Dual Low Flow Drive Motors
- Sprinkler Systems
- Front Spray Bar Only
- Oil Cooler

Specifications

General

Hydraulically driven rotary angle broom
Available in 7' (84"), 8' (96"), 9' (108"), 10' (120"), 11' (132") and 12' (144") widths
Hydraulic swing capable of 30° left or right of center
Broom speed up to 250 RPM, dependent on prime mover
Storage stands for simple mounting, dis-mounting, and storage
Brush head is lifted by means of the prime mover
Hoses provided from hydraulic drive motors to bulkhead or valve on broom
Customer must supply hoses from bulkhead or valve to prime mover
Sight Indicator Flags

Brush

32" O.D x 10" I.D wafer style brush
2" spacers manufactured from 20-gauge mild steel strap
Brush core can be installed with either end to the left or right with no effect on sweeping performance
Brush and core assembly can be removed from frame without disconnecting hoses from drive motor(s)
Quick change brush core

Brush Frame

3½" O.D. round tubular cross member
Two brush arms formed from ¼" steel plate
Rectangular front support bar for additional frame strength
Adjustable link to compensate brush pattern from wear

Brush Hood

Manufactured from 16- Gauge steel with formed edge fold for additional strength
12-Gauge steel end plates
Hood covers 145° of brush
Pre-drilled holes for easy installation of front deflector

Brush Drive

Standard with dual low-speed, high-torque, 18 c.i.d hydraulic motors
Motors are coupled directly to the brush core by means of a 5-5/16" poly hexagonal hub
Motors are recessed into brush frame to protect from collision

Castors

Two 16 ½" x 8, Solid rubber casters mounted behind the brush frame
360° of maneuverability
Sealed and greaseable 2" OD caster stem

Finish

Steel surfaces undergo a phosphatizing acid bath to clean and etch the surfaces to provide superior adhesion
Epoxy primer and polyurethane topcoat
Painted M-B yellow

*Standard model TKH-T

Hydraulic Broom for Tractors

7-foot (84") Broom

Poly/Wire Brush

Standard Dual Motor (28 to 40 GPM)

Hydraulic Swing Cylinder ONLY

Category I or II Three Point Hitch

Available Options

Broom Width

- 8-foot (96") Broom
- 9-foot (108") Broom
- 10-foot (120") Broom
- 11-foot (132") Broom
- 12-foot (144") Broom

Brush Filament

- Poly (Polypropylene) -

Dual Motor Size

- Low Flow (16 - 24 GPM)

Method of Swing (Typically operated by tractor controls)

- Electric/Hydraulic Swing
(Valve and control box with harness; MAX 40GPM)

Mounting Kit

- Custom Mount Design Fee (Actual cost of mount will be based after design)

Optional Equipment

- Independent Hydraulic system (IHS) (See Power Packs)
- Deflector (number of feet needed)
- Spray Bar Only with Nozzles (number of feet needed)
- 150 Gallon Three-Point Mount Sprinkler System
(Cannot be mounted to brush hood or used with rear 3 Point mounted TKH)
- 45 Gallon Sprinkler System (mounted on the brush hood)
- Parallel Arm Floation System
Oil Cooler with Fan

Recommended Spare Parts (for current pricing refer to the online Parts Guide at www.m-bco.com/attachments)

Part Number	Description
100-140381	Hub Assembly, Caster Wheel
100-140383	Seal, Grease, Caster Hub
100-176776	Wheel & Tire Assembly, Caster
201-176962	Motor LH
201-176963	Motor RH
383-132568	Pin, Swing Cylinder
400-64724	End Disc, Core
400-83521	Cylinder, Swing
401-176753	Caster Wheel Bolt
401-176923	Hub Hex, Urethane
401-176927	Motor Mount
410-126149	Pin, Swing, Pivot Frame
410-176750	Caster Fork, W.U. TKH
410-94050	Stand, Storage
603-75914	Bearing, Flanged, Caster Mounting

For brush replacements see "Replacement Brush Guide" section or online at www.m-bco.com

www.m-bco.com



1.800.558.5800

Note: Additional fees may apply (freight, export fees, dealer or factory installed hoses, valves and couplers, installation and service fees).
Equipment and products shown in this literature are for demonstration purposes only. Actual products offered for sale may vary in use, design, requirements and safety features.
M-B Companies reserves the right to improve our products and make revisions in designs, specifications and standards for equipment without notice and without incurring obligations.
M-B® is a registered trademark of M-B Companies, Inc. © 2019 M-B Companies, Incorporated. All Rights Reserved. 2019 M-B Attachments Product Guide Effective 7/1/19



VILLAGE OF PLOVER

2400 POST ROAD - PO Box 37 - PLOVER, WISCONSIN 54467
WWW.PLOVERWI.GOV

POPPY DAY PROCLAMATION

- WHEREAS,** *America is the land of the Free, preserved and protected by citizen Soldiers willingly and freely, and;*
- WHEREAS,** *millions who have answered the call to arms have died on the Field of Battle; and*
- WHEREAS,** *a nation at peace must be reminded of the price of war and the debt owed to those who have died in war; and*
- WHEREAS,** *the red poppy has been designated as a Symbol of Sacrifice of lives in all wars; and*
- WHEREAS,** *the American Legion Auxiliary has pledged to remind America annually of this debt through the distribution of the memorial flower.*

NOW, THEREFORE, I Gary Wolf, President of the Village of Plover, do hereby proclaim
May 15th, 2026 as

POPPY DAY

in the Village of Plover, and ask all citizens to pay tribute to all those who have made the ultimate sacrifice in the name of freedom by wearing the Memorial Poppy on this day.

IN WITNESS, *I have hereunto set my hand and caused to be affixed the official seal of the Village of Plover, Portage County, Wisconsin this 6th day of May, in the year of our Lord, two thousand and twenty-six.*

Gary Wolf



VILLAGE OF PLOVER

2400 POST ROAD - PO Box 37 - PLOVER, WISCONSIN 54467
WWW.PLOVERWI.GOV

To: Village Board Members
From: Tammy Wojtalewicz, Village Clerk
CC: Steve Kunst
Date: April 23, 2026
Re: Six Month Retail Liquor License Renewals

Following is a list of those applicants for Retail Alcohol Beverage Licenses renewals for a six-month period in 2026. No retail fermented malt beverage may be issued to any applicant indebted for the purchase of beer in excess of 15 days and no retail intoxicating liquor license may be issued to any applicant indebted for the purchase of intoxicating liquor in excess of 30 days. As is required by State Statute, all renewal applications being acted on at this week's meetings have been published three consecutive times to allow wholesale distributors the opportunity to send a delinquency notice to this office. I haven't received any to date for the applicants below.

Six Month Retail Liquor License applicants for 2026 are as follows:

Class "B" Retailers Fermented Malt Beverage License

1. Agent Craig Sankey, Plover American Legion Post 543, 2725 Roosevelt Dr.
2. Agent Josh Trzebiatowski, Plover Whiting Youth Athletics Inc., 2381 Cedar Dr.



VILLAGE OF PLOVER

2400 POST ROAD - PO Box 37 - PLOVER, WISCONSIN 54467
WWW.PLOVERWI.GOV

To: Village Board Members
From: Tammy Wojtalewicz, Village Clerk
CC: Steve Kunst
Date: April 29, 2026
Re: Shared Ride Taxi – Quarterly Report

The 2026 first quarter report for the Shared Ride Taxi Service is being provided to you as a requirement of the grant from the State of Wisconsin.

This is for information only. No action is needed.



SECTION 5311 OPERATING ASSISTANCE – Quarterly Requisition and Certification

Wisconsin Department of Transportation
DT63 3/2018

1. Grantee Municipality Village of Plover				
2. Address 2400 Post Road, P.O. Box 37		City Plover		State WI
		ZIP Code 54467		
3. Project Year 2026		4. Date of Claim 04/29/2026		5. Type of Requisition - Check One <input checked="" type="checkbox"/> Progress Payment <input type="checkbox"/> Final Payment
6. Period Covered (Check One)				
1 st Quarter <input checked="" type="checkbox"/> Jan. 1–Mar. 31	2 nd Quarter <input type="checkbox"/> Apr. 1–June 30	3 rd Quarter <input type="checkbox"/> July 1–Sept. 30	4 th Quarter <input type="checkbox"/> Oct. 1–Dec. 31	<input type="checkbox"/> Year-End

7. Cash disbursed on project year's expenses	\$108,253.66
8. Less Project Revenue	\$12,859.00
Contra Expenses	\$
9. Net Project Expenses (Item 7 minus item 8)	\$95,394.66
10. Amount Eligible for Reimbursement (Contract % x Item 9)	\$47,697.33

11. Certification: I certify that the cash disbursements shown above have been made for the period indicated and that payment is due and has not been previously requested.



 (Signature of Authorized Municipal Official)

4/29/2026

 (Date)

Name of Authorized Municipal Official Steve Kunst	Title Village Administrator	Area Code - Telephone Number 715-345-5250
--	--------------------------------	--

12. STATE AGENCY AUTHORIZATION	Project Maximum	\$
	Project to Date	\$
	This Requisition	\$
	Balance	\$

Charge To: _____ Pay This Amount \$

Project ID	FY	Responsibility	Function	Class
04 18		08 06 00	89	5100

V.OF PLOVER ENGINEER REPORT

submitted May 1, 2026

DESIGN PROJECTS

STH 54 Parallel Sanitary Interceptor

2/27/26: Design is complete. Project is being held open until project is let for bid by WisDOT.

Technical Specifications

2/2/26: Work has started on the Plover Technical Specifications project. An index is being created that is organized and numbered as a hybrid of WisDOT and APWA. When the index is complete, it will be reviewed by Village department heads before work continues.

2/27/26: The index is drafted and is being reviewed prior to forwarding to Village department heads.

3/12/26: The index has been forwarded to Village department heads for comment.

4/10/26: Department head comments have been received. Content work will continue.

5/01/26: No new information to report

CONSTRUCTION PROJECTS

Green Tree Farms subdivision

4/10/26: A preconstruction meeting was held March 30. Construction is anticipated to start mid-April. DNR NOI permits have been received, so clearing and grading work can proceed. Sanitary and water permits are pending. Plan updates to address Village comments are still pending.

5/01/26: Contractor is clearing the site. AECOM field staff have set some survey control points. No utility materials are yet on site.

DEVELOPMENT PROJECTS

MULLINS CHEESE

10/10/25: We are expecting updated utility and stormwater plans due to the decision not to vacate a portion of Corporate Ave.

5/01/26: No new information to report

Empire Estates

2/2/26: Utility plans were submitted on 1/9/26 and stormwater plans were submitted on 1/16/26. Plans have been reviewed. A conditional recommendation to accept plans for both the utilities and stormwater plans was sent to Village staff and the development team on 2/2/2026. Conditions include minor adjustments to the utilities and some clarifications on the stormwater plan. A task order for construction services is being developed, anticipating start of construction mid-April.

2/27/26: Due to the developer pausing requests for approval, the task order development for construction services has been paused.

3/12/26: Updated plans have been submitted and comments have been satisfied.

4/10/26: A task order for construction inspection services has been submitted. The developer has put the project on HOLD for the time being.

5/01/26: No new information to report

Green Tree Farm

2/2/26: The developer submitted plans for a pre-submittal review on 12/15/25. Utility and stormwater plans were submitted on 1/19/26 for review. Those plans are currently under review.

2/27/26: Plans have been reviewed and comments for revisions submitted to the developer. A task order for construction services is being developed, including the inspection of stormwater management features at the developer's request.

3/12/26: Plans have been resubmitted for review. A task order for construction observation has been submitted.

4/10/26: Utility and stormwater plans have a few minor issues that need to be addressed.

5/01/26: No new information to report

Portage County Facility

8/29/25: A preliminary concept plan has been received for review

9/12/25: Some additional preliminary plan information has been received. Providing sanitary sewer will require some evaluation and direction. Some high-level cost estimates and location of sanitary sewer as compared to Plover's sanitary sewer master plan have been discussed between AECOM engineers and Village staff. A preliminary review meeting was facilitated by Village staff on 9/10/25.

4/10/26: Updated civil/site plans have been submitted for review. Village staff met on March 30 to discuss with the County and their engineers. An aggressive design/construction calendar for utility work has been proposed.

5/01/26: No new information to report

Crossroad Commons Commercial Development

12/12/25: A preliminary certified survey/plat was reviewed for a new proposed commercial development in Crossroads Commons. Comments were forwarded to the developer.

The stormwater ponds serving Crossroads Commons are designed to handle a specific amount of impervious surfaces (pavement, buildings, etc.) As the business park is nearing capacity, available stormwater capacity is being checked for each potential development. The pond Infiltration rate during the 2025 calendar year demonstrates that the ponds are in need of maintenance. This work should be planned and budgeted to prevent stormwater control issues.

1/16/26: The Developer has indicated they are reconfiguring the lot layout to minimize potential groundwater conflicts, increase proximity to the stormwater management ponds, and improve utility access.

5/01/26: No new information to report

GENERAL

Other

1/16/26: Review of State regulations pertaining to planning and consideration of future ice control brine storage.

4/10/26: SPRINGVILLE DAM - The Wisconsin Department of Natural Resources (DNR) has issued its response to the 2025 inspection of the Springville Dam (see attached letter). Although the inspection did **not** identify any operational or maintenance problems, and no issues were noted beyond normal routine upkeep, the DNR has assigned the dam a “**Poor**” rating. Their rating is based on what they describe as “uncertainties with embankment stability and internal erosion during both normal and higher-than-normal water conditions.”

In addition, the DNR is now requiring the Village to complete a **Potential Failure Mode Analysis (PFMA)**. This analysis is intended to evaluate the possibility of internal erosion or instability related to seepage at bolt holes and joints in the outlet structure.

It is important to note the following:

- The bolt-hole leakage observed after construction **was repaired** by the contractor in 2024 by sealing the holes with grout.
- Minor joint seepage **was expected** with the current box-culvert style outlet structure. This structure was not part of the original design; it was redesigned at the direction of the Wisconsin Department of Transportation to allow phased construction.
- Box-culvert joints are known to allow some seepage. To safely manage this, **filter fabric** was installed at the joints to let clean water pass through while preventing soil movement and erosion.
- The surrounding native soils are highly permeable, and the design includes **two clay seepage collars** around the outlet structure to prevent water from traveling along the outside of the structure.

PFMAs are normally required only for dams regulated by the **Federal Energy Regulatory Commission (FERC)**. The Springville Dam is **not federally regulated**, and state-regulated dams are instead required to follow Wisconsin **NR 333** rules. There is **no language in NR 333**, nor any known state administrative rule, that requires or authorizes the DNR to mandate a PFMA for state-regulated dams.

The Village already has all required state-approved documents in place, including:

- A **Dam Failure Analysis (DFA)**
- An **Emergency Action Plan (EAP)**
- An **Inspection, Operation, and Maintenance Plan (IOM)**

To be proactive and as agreed to between the Village and the DNR, the Village is also conducting **monthly inspections**—in addition to the normal every-other-year cycle—to monitor seepage for any signs of sediment movement related to joint seepage in the outfall structure. **No sediment has ever been observed** at any seepage location.

The Village has contacted the DNR to request:

1. An explanation of what evidence suggests that any internal or external erosion may be occurring,
2. Examples of PFMA reports for other state-regulated dams, and
3. A meeting with DNR staff to discuss the basis for their concerns.

5/01/26: Springville Dam - A meeting date has been tentatively set to meet with the DNR for Thursday, June 4 at 10:00 am.